

The Bloques Package

Alejandro Garces Ruiz
alejandrogarc@gmail.com

I. FUNCTIONS

The **bloques** package is a very simple set of commands based on **tikz** to generate control blocks. The only packages required in the definition are:

```
\usepackage{tikz}
\usepackage{bloques}
```

The package is very efficient for sequential blocks as follow:

```
\bStart{TEXT}
\bPlusDown{TEXT}
\bPlusUp{TEXT}
\bMinusDown{TEXT}
\bMinusUp{TEXT}
\bEnd{TEXT}
\bGain{TEXT}

\bGainPlus{TEXT1}{TEXT2}
\bGainMinus{TEXT1}{TEXT2}
```

For Feedback controls, it is required to mark the nodes with the following functions:

```
\bMinusF{NODENAME}
\bPlusF{NODENAME}
\bFeedBack{TEXT}{NODENAME}
\bCrossGain{TEXT}{NODENAME1}{NODENAME2}
\bNewStart{TEXT}{POSITION}
\bMarkNode{NODENAME}
\bMarkNodeUp{NODENAME}
\bMarkNodeDown{NODENAME}
```

To change colors and distances, the following functions are available

```
\bShadow{NUMBER} % default = 0
\bColorB{COLOR} % default = white
\bColorT{COLOR} % default = black
\ydistance{NUMBER} % default = 1.2 cm
```

II. EXAMPLES

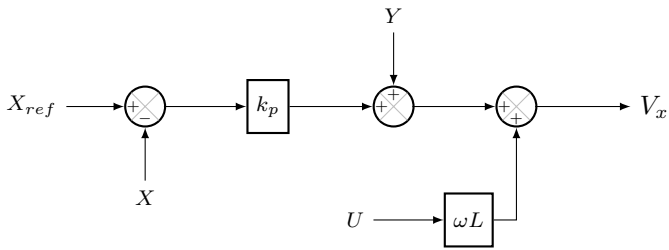

Fig. 1. Simple Control diagram

```

\begin{figure}
\begin{tikzpicture}
  \bStart{$X_{ref}$}
  \bMinusDown{$X$}
  \bGain{$k_p$}
  \bPlusUp{$Y$}
  \bGainPlus{$U$}{$\omega L$}
  \bEnd{$V_x$}
\end{tikzpicture}
\end{figure}

```

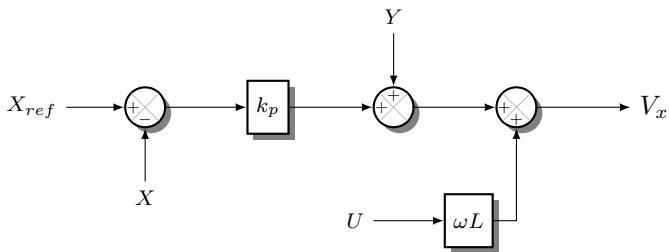

Fig. 2. Control diagram with shadow

```

\begin{figure}
\begin{tikzpicture}
  \bShadow
  \bStart{$X_{ref}$}
  \bMinusDown{$X$}
  \bGain{$k_p$}
  \bPlusUp{$Y$}
  \bGainPlus{$U$}{$\omega L$}
  \bEnd{$V_x$}
\end{tikzpicture}
\end{figure}

```

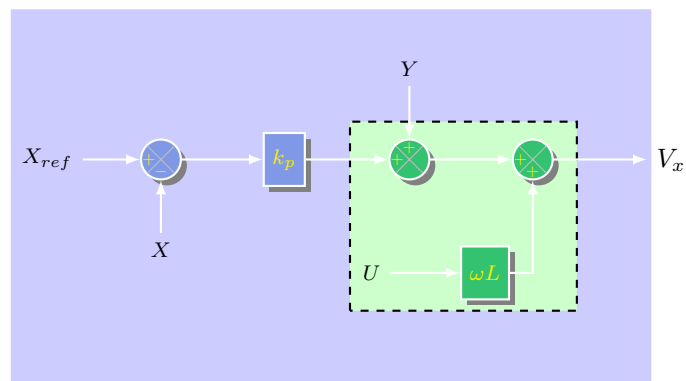

Fig. 3. Control diagram with shadow and different colors

```

\begin{figure}
\begin{tikzpicture}[thick]
  \draw[fill=blue!20, draw=white]
    (-0.5,-3) rectangle (8,2);
  \draw[fill=green!20, dashed]
    (4,-2) rectangle (7,0.5);

  \bShadow
  \bColorB{blue!50!green!45}
  \bColorT{yellow}
  \bColorL{white}
  \bStart{$X_{ref}$}
  \bMinusDown{$X$}
  \bGain{$k_p$}
  \bColorB{blue!30!green!80}
  \bPlusUp{$Y$}
  \bGainPlus{$U$}{$\omega L$}
  \bEnd{$V_x$}
\end{tikzpicture}
\end{figure}

```

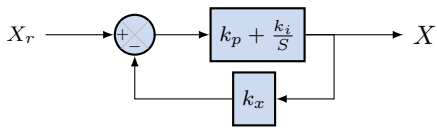

```

\begin{figure}
\begin{tikzpicture}
  \bColorB{blue!70!green!20}
  \bStart{\$X_{r}\$}
  \bMinusF{NODEX}
  \bGain{\$k_{p}+\frac{k_{i}}{S}\$}
  \bFeedBack{\$k_{x}\$}{NODEX}
  \bEnd{\$X\$}
\end{tikzpicture}
\end{figure}

```

Fig. 4. Control diagram with feedback

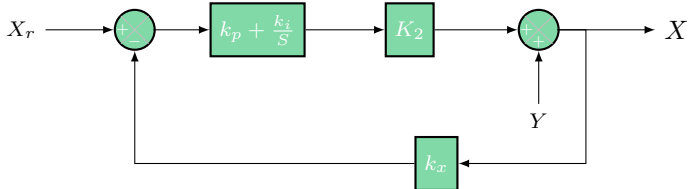

```

\begin{figure}
\begin{tikzpicture}
  \bColorB{blue!30!green!50}
  \bColorT{white}
  \bStart{\$X_{r}\$}
  \bMinusF{NODEX}
  \bGain{\$k_{p}+\frac{k_{i}}{S}\$}
  \bGain{\$K_{2}\$}
  \bPlusDown{\$Y\$}
  \ydistance{2.5cm}
  \bFeedBack{\$k_{x}\$}{NODEX}
  \bEnd{\$X\$}
\end{tikzpicture}
\end{figure}

```

Fig. 5. Change the ydistance

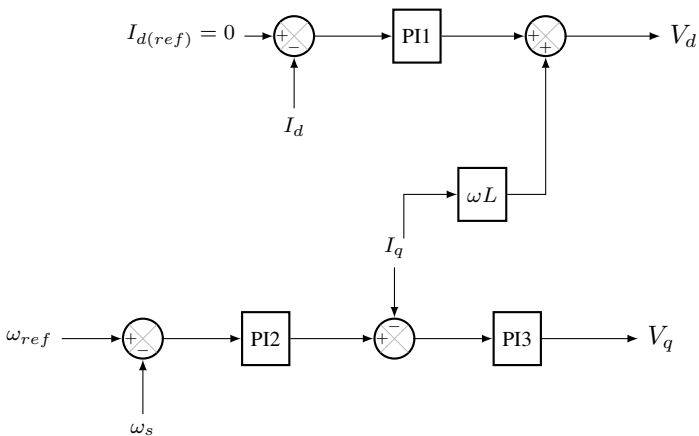

```

\begin{figure}
\begin{tikzpicture}
  \bStart{\$I_{d(ref)}=0\$}
  \bMinusDown{\$I_{d}\$}
  \bGain{PI1}
  \bPlusF{NODET}
  \bEnd{\$V_{d}\$}
  \bNewStart{\$\omega_{ref}\$}{(-2,-4)}
  \bMinusDown{\$\omega_{s}\$}
  \bGain{PI2}
  \bMinusUp{\$I_{q}\$}
  \bMarkNodeUp{NODEX}
  \bGain{PI3}
  \bEnd{\$V_{q}\$}
  \bCrossGain{\$\omega L\$}{NODEX}{NODET}
\end{tikzpicture}
\end{figure}

```

Fig. 6. More complex controls